

SUPERTALENT ULTRADRIVE GX DATASHEET

2.5" SATA-II SOLID STATE DRIVE



Copyright ©, Property of Super Talent Technology. All rights reserved. The information and specification provided in this document should be used for comparative analysis and reference purposes. The contents of this document are subject to change without prior notice.

TABLE OF CONTENTS

Table of Figures..... 4

Table of Tables 4

1.0 product description..... 6

 1.1 Product Overview 6

 1.2 Target Applications 6

 1.3 Product Features..... 6

 1.4 System Requirements 7

2.0 Product Ordering Part Numbers 7

 2.1 Ordering Part Structure 7

 2.2 Valid Ordering Part Numbers..... 7

3.0 Physical Specifications 8

4.0 Electrical Specifications..... 9

 4.1 Performance Specifications 9

 4.2 Absolute Maximum Ratings..... 10

 4.3 Power Consumption 10

5.0 Environmental Specifications 11

6.0 Quality and Reliability Specifications..... 11

7.0 Compliance Specifications 12

8.0 Pin Descriptions 12

 8.1 Data Pin Assignments 12

 8.2 Power Pin Assignments..... 12

9.0 Supported ATA Command Set 13

10.0 S.M.A.R.T. Support Overview.....	14
10.1 S.M.A.R.T. Subcommand Sets.....	14
10.2 S.M.A.R.T. Read Data (Subcommand D0h).....	14
10.3 S.M.A.R.T. Enable/Disable Attribute Autosave (Subcommand D2h).....	15
10.4 S.M.A.R.T. Save Attribute Values (Subcommand D3h).....	15
10.5 S.M.A.R.T. Execute Off-Line Immediately (Subcommand D4h).....	16
10.6 S.M.A.R.T. Read Log Sector (Subcommand D5h).....	16
10.7 S.M.A.R.T. Write Log Sector (Subcommand D6h).....	20
10.8 S.M.A.R.T. Enable Operations (Subcommand D8h).....	20
10.9 S.M.A.R.T. Disable operations (Subcommand D9h).....	20
10.10 S.M.A.R.T. Return Status (Subcommand DAh).....	20
10.11 S.M.A.R.T. Enable/Disable Automatic Off-line (subcommand DBh).....	21
11.0 Security	21
11.1 Default Setting	21
11.2 Initial Setting of the User Password.....	22
11.3 Security Mode Operation From Power On	22
11.4 Password Lost	22
12.0 SATA Optional Features	22
12.1 Power Segment Pin P11	22
12.2 Asynchronous Signal Recovery	22
12.3 Native Command Queuing.....	23
13.0 Identify Device Parameters.....	24
14.0 Installation	26

For More Information	28
Change Record	29

TABLE OF FIGURES

Figure 1: 2.5" SSD Outline Drawing	8
--	---

TABLE OF TABLES

Table 1: Ordering Part Structure.....	7
Table 2: Valid Ordering Part Numbers.....	7
Table 3: Data Transfer Time Specifications	9
Table 4: Absolute Maximum Ratings	10
Table 5: FTD28GX25M Active Current Ratings	10
Table 6: Calculated FIT Rates by Device.....	11
Table 7: Data Pin Signal Assignment.....	12
Table 8: Power Pin Signal Assignment	12
Table 9: Serial ATA Supported Command Set.....	13
Table 10: SMART Subcommand Set.....	14
Table 11: Device Attribute Data Structure	14
Table 12: Individual Attribute Data Structure	15
Table 13: Attribute ID Numbers.....	15
Table 14: LBA Low Register Definition	16
Table 15: Read Log Sector Register Definition.....	16
Table 16: SMART Log Directory	17
Table 17: SMART Summary Error Log Sector.....	17

Table 18: Error Log Data Structure	17
Table 19: Command Data Structure	18
Table 20: Error Data Structure	18
Table 21: State Field Values	18
Table 22: Self-test Log Structure.....	19
Table 23: Selective Self Test Log Structure	19
Table 24: Sector Count Register Definition.....	21
Table 25: Identify Device Parameters.....	26
Table 26: Change Record	29

1.0 PRODUCT DESCRIPTION

1.1 PRODUCT OVERVIEW

A Solid State Disk (SSD) is a storage device that is based on semiconductors rather than rotating magnetic platters. Most SSDs, including Super Talent's UltraDrive offerings, are based on NAND Flash chips because they are fast, highly reliable, widely available and non-volatile.

SSDs are 100% compatible with standard hard disk drives, and have both industry standard dimensions and a standard hard drive SATA 3Gbps (a.k.a. SATA-II) interface. While typical spinning HDDs are the weakest point when it comes to withstanding extremes in a PC, Server, Workstation, or Datacenter, an SSD drive is often one of the most reliable components in those environments. Along with its durability and reliability, the SSD delivers unparalleled performance.

1.2 TARGET APPLICATIONS

- Military and Aerospace
- Enterprise Computing
- Embedded / Industrial Systems
- Notebook
- Medical Industry
- Casino Gaming

1.3 PRODUCT FEATURES

- Capacity: 32-256GB
- 64MB Internal Cache
- Form Factor: 2.5" HD (100.20mm x 69.85mm x 9.5mm)
- MLC or SLC Flash
- Fully compliant with SATA revision 2.6
 - Compatible with SATA 3.0Gb/s and SATA 1.5Gb/s interfaces
- Fully compliant with ATA-7 Standard
- PIO, DMA, UDMA (up to 6, dependent on host) supported
- Rugged Metal Case
- Minimum 10 year data retention
- Built in wear leveling algorithm
- Built in error detection and correction
- 100% tested HW and SW
- Designed and Manufactured in USA

1.4 SYSTEM REQUIREMENTS

Operating Voltage Requirement: $V_{cc} = 5.0V \pm 10\%$

Operating System: Supported by all Operating Systems

Interface: SATA 3.0Gbps (SATA-II) or SATA 1.5Gbps (SATA-I)

Installation Requirements:

- System Mounting Hardware as required
- 15Pin SATA Power cable
- 7Pin SATA Data cable

2.0 PRODUCT ORDERING PART NUMBERS

2.1 ORDERING PART STRUCTURE

Prefix X	Product Type XX	Density XXX	Technology X	Form Factor XX	Casing X
F - Channel	TD - SATA-II SLC TM - SATA-II MLC	16G - 16GByte 32G - 32GByte 64G - 64GByte 28G - 128GByte 56G - 256GByte	X - UltraDrive	25 - 2.5"	H - Metal Case

Table 1: Ordering Part Structure

2.2 VALID ORDERING PART NUMBERS

Product Family	Capacity	Flash	Form Factor	Casing	Channel/Retail Part Number
UltraDrive GX	32GB	MLC	2.5"	Metal	FTM32GX25H
	64GB	MLC	2.5"	Metal	FTM64GX25H
	128GB	MLC	2.5"	Metal	FTM28GX25H
	256GB	MLC	2.5"	Metal	FTM56GX25H
	32GB	SLC	2.5"	Metal	FTD32GX25H
	64GB	SLC	2.5"	Metal	FTD64GX25H
	128GB	SLC	2.5"	Metal	FTD28GX25H

Table 2: Valid Ordering Part Numbers

3.0 PHYSICAL SPECIFICATIONS

Length: 100.20 ± 0.25 mm

Width: 69.85 ± 0.25 mm

Thickness: 9.50 ± 0.25 mm

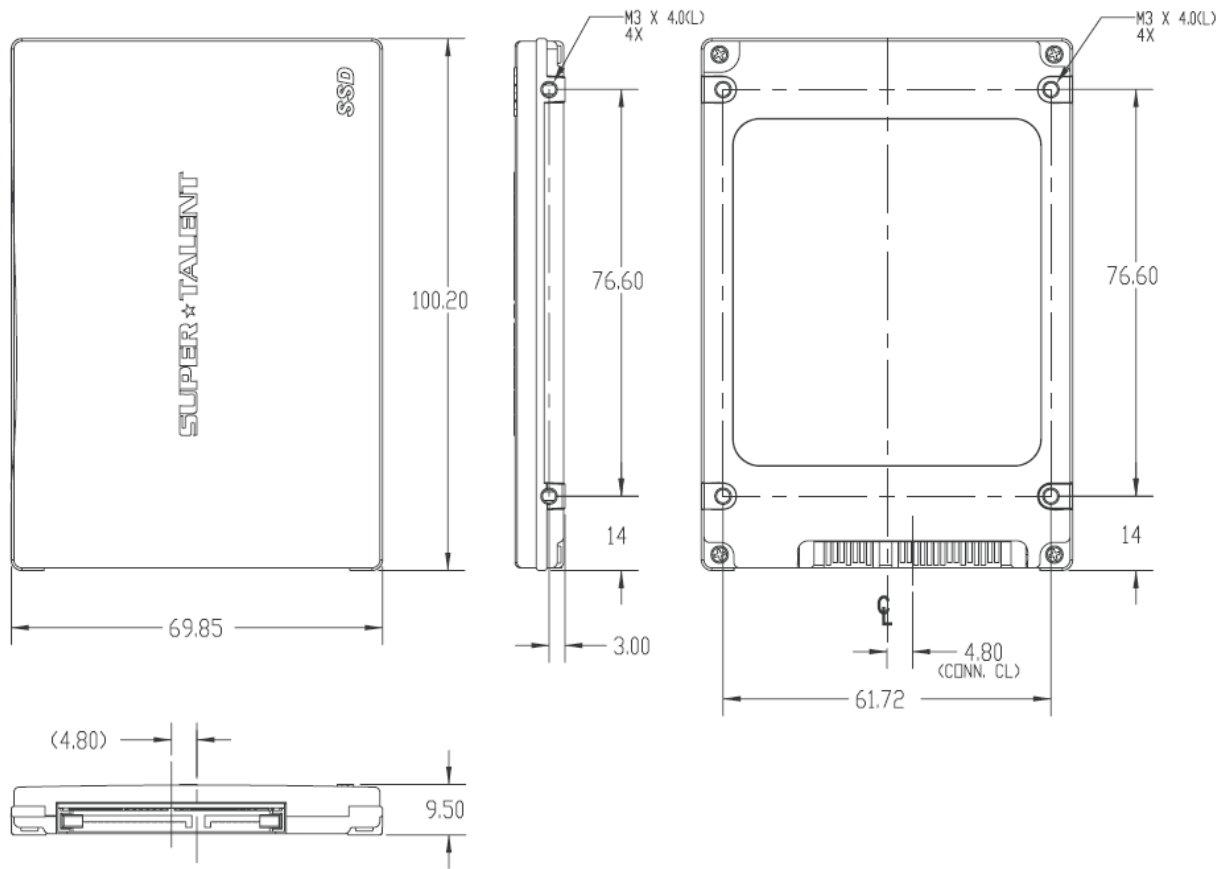

Figure 1: 2.5" SSD Outline Drawing

4.0 ELECTRICAL SPECIFICATIONS

Operating Voltage: $V_{cc} = 5.0V \pm 10\%$

Sector Size: 512Bytes

Modes: PIO, DMA, UDMA (up to 6, dependant host)

4.1 PERFORMANCE SPECIFICATIONS

Access Time: 0.1 ms

Seek Time: 0 ms

Mount Time: Dependent on system HW and SW

Read Latency: 50 μs (Typical)

Write Latency: 100 μs (Typical)

Power on to Ready: 0.5 seconds (Max)

Data Transfer Time: Rated Data Transfer Speeds are maximums based on ATTO 128KB transfers. IOPS are based on IOMETER with 4KB transfer size.

Device	Sequential Read Max (MB/Sec)	Sequential Write Max (MB/Sec)	Sequential Read Max (IOPS)	Sequential Write Max (IOPS)	Random Read Max (IOPS)	Random Write Max (IOPS)
FTM32GX25H	230	160	TBD	TBD	TBD	TBD
FTM64GX25H	230	180	11000	16000	6500	3600
FTM28GX25H	260	195	11000	16000	6500	3800
FTM56GX25H	260	200	10500	15300	6500	4500
FTD32GX25H	230	170	TBD	TBD	TBD	TBD
FTD64GX25H	260	210	13000	16000	7500	6000
FTD28GX25H	260	210	13000	16000	7500	5000

Table 3: Data Transfer Time Specifications

Performance is highly dependent upon test environment and use case. Consult our benchmarking data for more detailed performance information or benchmark performance in your environment.

4.2 ABSOLUTE MAXIMUM RATINGS

Symbol	Rating	Value	Unit
V _{CC}	Power Supply Voltage	-0.5 to 6.5	V
V _{IN}	Input Voltage	-0.5 to V _{CC} +0.5	V
T _{STG}	Storage Temperature	-55 to 115	°C
T _{OPR}	Operating Temperature	0 to 70	°C

Table 4: Absolute Maximum Ratings

4.3 POWER CONSUMPTION

Currently SuperTalent is only specifying power consumption on the FTD28GX25M in Table 5: FTD28GX25M Active Current Ratings, which is one of the more power hungry models in the family. SuperTalent is providing power consumption numbers upon request. Please send your request to Support@supertalent.com Subject: SSD Marketing.

Symbol	Parameter	Min	Typ.	Max	Unit
I _{BOOT}	Boot-Up Current	-	307	-	mA
I _{CCS}	Idle Mode Current	78	78	78	mA
I _{CCSR4}	4K Sequential Read Current	106	111	116	mA
I _{CCSR256}	256K Sequential Read Current	185	205	206	mA
I _{CCRR4}	4K Random Read Current	96	97	97	mA
I _{CCRR256}	256K Random Read Current	96	97	97	mA
I _{CCSW4}	4K Sequential Write Current	140	141	143	mA
I _{CCSW256}	256K Sequential Write Current	236	251	320	mA
I _{CCRW4}	4K Random Write Current	170	175	179	mA
I _{CCRW256}	256K Random Write Current	255	268	280	mA

Table 5: FTD28GX25M Active Current Ratings

Note: All current measurements taken at V_{CC}=5V

5.0 ENVIRONMENTAL SPECIFICATIONS

Operating Temperature: Commercial Temp Range Only

- Commercial 0°C to 70°C

Humidity: 5% to ~98% RH

Operating Shock: 1500G

Operating Vibration: 16G

Operating Altitude: TBD

6.0 QUALITY AND RELIABILITY SPECIFICATIONS

Data Retention: Minimum of 10 years

Wear Leveling: Dynamic and static wear-leveling

Bad Block Management: Drive will self identify bad blocks and remap physical to logical addresses to avoid bad blocks.

ECC/EDC (Error Correction Code/Error Detection Code): Built in error detection and correction will correct physical bit errors in NAND.

MTBF: >1,000,000 hours

FIT Rate:

Device	FIT Rate
FTM32GX25H	160
FTM64GX25H	320
FTM28GX25H	640
FTM56GX25H	1280
FTD32GX25H	320
FTD64GX25H	640
FTD28GX25H	1280

Table 6: Calculated FIT Rates by Device

Power Cycle: TBD

Note: MTBF and FIT Rate calculated based on component values

7.0 COMPLIANCE SPECIFICATIONS

All UltraDrives are compliant with the following standards and regulations:

- RoHS
- CE
- FCC
- MIC

8.0 PIN DESCRIPTIONS

8.1 DATA PIN ASSIGNMENTS

Pin	Symbol	Description
S1	GND	
S2	RxP	Differential Signal Pair for Receiver
S3	RxN	Differential Signal Pair for Receiver
S4	GND	
S5	TxN	Differential Signal Pair for Transceiver
S6	TxP	Differential Signal Pair for Transceiver
S7	GND	

Table 7: Data Pin Signal Assignment

8.2 POWER PIN ASSIGNMENTS

Pin	Symbol	Description
P1	Not Used (3.3V)	N/A
P2	Not Used (3.3V)	N/A
P3	Not Used (3.3V Precharge)	
P4	GND	1 st mate
P5	GND	2 nd mate
P6	GND	
P7	5V Precharge	5V Power
P8	5V Precharge	5V Power
P9	5V Precharge	
P10	GND	
P11	Reserved	
P12	GND	1 st mate
P13	Not Used (12V Precharge)	N/A
P14	Not Used (12V)	
P15	Not Used (12V)	

Table 8: Power Pin Signal Assignment

9.0 SUPPORTED ATA COMMAND SET

Command Name	Code (Hex)	Command Name	Code (Hex)
CHECK POWER MODE	E5h or 98h	Disable write cache	EFh/82h
DEVICE CONFIGURATION	-	Set transfer mode	EFh/03h
DEVICE CONFIGURATION FREEZE LOCK	B1h/C1h	Enable DMA Setup FIS Auto-Activate optimization	EFh/10h/02h
DEVICE CONFIGURATION IDENTIFY	B1h/C2h	Disable DMA Setup FIS Auto-Activate optimization	EFh/90h/02h
DEVICE CONFIGURATION RESTORE	B1h/C0h	Enable Device-initiated interface power state transitions	EFh/10h/03h
DEVICE CONFIGURATION SET	B1h/C3h	Disable Device-initiated interface power state transitions	EFh/10h/03h
DOWNLOAD MICROCODE	92h	SET MAX	-
EXECUTE DEVICE DIAGNOSTIC	90h	SET MAX ADDRESS	F9h/na
FLUSH CACHE	E7h	SET MAX FREEZE LOCK	F9h/04h
FLUSH CACHE EXT	EAh	SET MAX LOCK	F9h/02h
IDENTIFY DEVICE	ECh	SET MAX SET PASSWORD	F9h/01h
IDLE	E3h or 97h	SET MAX UNLOCK	F9h/03h
IDLE IMMEDIATE	E1h or 95h	SET MAX ADDRESS EXT	37h
INITIALIZE DEVICE PARAMETERS	91h	SET MULTIPLE MODE	C6h
NOP	00h/00h	SLEEP	E6h or 99h
READ BUFFER	E4h	SMART	-
READ DMA	C8h	SMART DISABLE OPERATIONS	B0h/D9h
READ DMA EXT	25h	SMART ENABLE OPERATIONS	B0h/D8h
READ FPDMA QUEUED	60h	SMART ENABLE/DISABLE ATTRIBUTE AUTOSAVE	B0h/D2h
READ LOG EXT	2Fh	SMART ENABLE/DISABLE AUTOMATIC OFF-LINE	B0h/DBh
READ MULTIPLE	C4h	SMART EXECUTE OFF-LINE IMMEDIATE	B0h/D4h
READ MULTIPLE EXT	29h	SMART READ DATA	B0h/D0h
READ NATIVE MAX ADDRESS	F8h	SMART READ LOG	B0h/D5h
READ NATIVE MAX ADDRESS EXT	27h	SMART RETURN STATUS	B0h/DAh
READ SECTOR(S)	20h	SMART SAVE ATTRIBUTE VALUES	B0h/D3h
READ SECTOR(S) EXT	24h	SMART WRITE LOG	B0h/D6h
READ VERIFY SECTOR(S)	40h	STANDBY	E2h or 96h
READ VERIFY SECTOR(S) EXT	42h	STANDBY IMMEDIATE	E0h or 94h
SECURITY DISABLE PASSWORD	F6h	WRITE BUFFER	E8h
SECURITY ERASE PREPARE	F3h	WRITE DMA	CAh
SECURITY ERASE UNIT	F4h	WRITE DMA EXT	35h
SECURITY FREEZE LOCK	F5h	WRITE FPDMA QUEUED	61h
SECURITY SET PASSWORD	F1h	WRITE LOG EXT	3Fh
SECURITY UNLOCK	F2h	WRITE MULTIPLE	C5h
SEEK	70h	WRITE MULTIPLE EXT	39h
SET FEATURES	-	WRITE SECTOR(S)	30h
Enable write cache	EFh/02h	WRITE SECTOR(S) EXT	34h

Table 9: Serial ATA Supported Command Set

10.0 S.M.A.R.T. SUPPORT OVERVIEW

10.1 S.M.A.R.T. SUBCOMMAND SETS

In order to select a subcommand the host must write the subcommand code to the device's Features Register before issuing the SMART Function Set command. The subcommands are listed in Table 10: SMART Subcommand Set.

Command Code	Command Code (Hex)
SMART READ DATA	D0h
SMART ENABLE/DISABLE ATTRIBUTE AUTOSAVE	D2h
SMART SAVE ATTRIBUTE VALUES	D3h
SMART EXECUTE OFF-LINE IMMEDIATE	D4h
SMART READ LOG	D5h
SMART WRITE LOG	D6h
SMART ENABLE OPERATIONS	D8h
SMART DISABLE OPERATIONS	D9h
SMART RETURN STATUS	DAh
SMART ENABLE/DISABLE AUTOMATIC OFF-LINE	DBh

Table 10: SMART Subcommand Set

10.2 S.M.A.R.T. READ DATA (SUBCOMMAND D0H)

This subcommand returns the device's Attribute Values to the host. The attribute values consist of 512bytes.

Byte	Description
0~1	Data structure revision number (Vendor Specific)
2~361	1st - 30th Individual attribute data (Vendor Specific)
362	Off-line data collection status
363	Self-test execution status
364~365	Total time in seconds to complete off-line data collection activity
366	Vendor Specific
367	Off-line data collection capability
368-369	SMART capability
370	Error logging capability 7:1 Reserved 0 1=Device error logging supported
371	Self-test failure check point (Vendor Specific)
372	Short self-test routine recommended polling time(in minutes)
373	Extended self-test routine recommended polling time(in minutes)
374-510	Reserved
511	Data structure checksum

Table 11: Device Attribute Data Structure

Byte	Description
0	Attribute ID Number
1~2	Status Flag
3~10	Attribute Value (FFFF FFFF FFFF FFFFh)
11	Reserved

Table 12: Individual Attribute Data Structure

ID	Attribute Name	ID	Attribute Name
1	Raw Read Error Rate *	198	Total Count of Read Sectors
9	Power-On Hours	199	Total Count of Write Sectors
12	Power Cycle Count	200	Total Count of Read Commands
184	Initial Bad Block Count	201	Total Count of Write Commands
195	Program Failure Block Count	202	Total Count of Error Bits from Flash
196	Erase Failure Block Count	203	Total Count of Read Sectors with Correctable Bit Errors
197	Read Failure Block Count (Uncorrectable bit errors)	204	Bad Block Full Flag

Table 13: Attribute ID Numbers

*Note: * indicates that the corresponding Attribute Value is a fixed value for compatibility.*

10.3 S.M.A.R.T. ENABLE/DISABLE ATTRIBUTE AUTOSAVE (SUBCOMMAND D2H)

The SMART Enable/Disable Attribute Autosave subcommand enables and disables the attribute auto save feature of the device. This subcommand may either allow the device to automatically save its updated Attribute Values to the Attribute Data Sector at the timing of the first transition to Active idle mode and after 15 minutes after the last saving of Attribute Values; or this subcommand may cause the Attribute Autosave feature to be disabled. The Sector Count register shall be set to specify the operation.

10.4 S.M.A.R.T. SAVE ATTRIBUTE VALUES (SUBCOMMAND D3H)

This subcommand causes the device to immediately save any updated Attribute Values to the device's Attribute Data sector regardless of the state of the Attribute Autosave feature.

10.5 S.M.A.R.T. EXECUTE OFF-LINE IMMEDIATELY (SUBCOMMAND D4H)

This subcommand causes the device to start the off-line process for the requested mode and operation. The LBA Low register as specified in Table 14: LBA Low Register Definition must be set to specify the operation to be executed.

LBA Low	Description
00h	Execute SMART off-line data collection routine immediately
01h	Execute SMART Short self-test routine immediately in off-line mode
02h	Execute SMART Extended self-test routine immediately in off-line mode
03h	Reserved
04h	Execute SMART Selective self-test routine immediately in off-line mode
40h	Reserved
7Fh	Abort off-line mode self-test routine
81h	Execute SMART short self-test routine immediately in captive mode
82h	Execute SMART Extended self-test routine immediately in captive mode
84h	Execute SMART selective self-test routine immediately in captive mode
C0h	Reserved

Table 14: LBA Low Register Definition

10.6 S.M.A.R.T. READ LOG SECTOR (SUBCOMMAND D5H)

This command returns the specified log sector content to the host. LBA Low and Sector Count Registers must be set to specify the log sector and sector number to be written.

Log Sector Address	No. Sector	Content	Type
00h	1	Log directory	Read Only
01h	1	SMART error log	Read Only
02h	1	Comprehensive SMART error log	Read Only
04h-05h	-	Reserved	Read Only
06h	1	SMART self-test log	Read Only
08h	-	Reserved	Read Only
09h	1	Selective self-test log	Read and Write
0Ah-7Fh	-	Reserved	Read Only
80h-9Fh	16	Host vendor specific	Read and Write
A0h-FFh	-	Reserved	Vendor Specific

Table 15: Read Log Sector Register Definition

Byte	Description
0~1	SMART Logging Version (set to 01h)
2	Number of sectors in the log at log address 1
3	Reserved
4	Number of sectors in the log at log address 2
5	Reserved
...	
510	Number of sectors in the log at log address 255
511	Reserved

Table 16: SMART Log Directory

Byte	Description
0	SMART error log version (set to 01h)
1	Error log index
2~91	First error log data structure
92~181	Second error log data structure
182~271	Third error log data structure
272~361	Fourth error log data structure
362~451	Fifth error log data structure
452~453	Device error count
454~510	Reserved
511	Data Structure checksum

Table 17: SMART Summary Error Log Sector

Byte	Description
n ~ n+11	First command data structure
n+12 ~ n+23	Second command data structure
n+24 ~ n+35	Third command data structure
n+36 ~ n+47	Fourth command data structure
n+48 ~ n+59	Fifth command data structure
n+60 ~ n+89	Error data structure

Table 18: Error Log Data Structure

Byte	Description
n	Content of the Device Control register when the Command register was written
n+1	Content of the Features Control register when the Command register was written
n+2	Content of the Sector Count Control register when the Command register was written
n+3	Content of the LBA Low register when the Command register was written
n+4	Content of the LBA Mid register when the Command register was written
n+5	Content of the LBA High register when the Command register was written
n+6	Content of the Device/Head register when the Command register was written
n+7	Content written to the Command register
n+8	Timestamp
n+9	Timestamp
n+10	Timestamp
n+11	Timestamp

Table 19: Command Data Structure

Byte	Description
N	Reserved
n+1	Content written to the Error register after command completion occurred.
n+2	Content written to the Sector Count register after command completion occurred.
n+3	Content written to the LBA Low register after command completion occurred.
n+4	Content written to the LBA Mid register after command completion occurred.
n+5	Content written to the LBA High register after command completion occurred.
n+6	Content written to the Device/Head register after command completion occurred.
n+7	Content written to the Status register after command completion occurred.
n+8 – n+26	Extended error information
n+27	State
n+28	Life Timestamp (least significant byte)
n+29	Life Timestamp (most significant byte)

Table 20: Error Data Structure

Value	State
x0h	Unknown
x1h	Sleep
x2h	Standby
x3h	Active/Idle with BSY cleared to zero
x4h	Executing SMART off-line or self-test
x5h-xAh	Reserved
xBh-xFh	Vendor unique

Table 21: State Field Values

Byte	Description
0~1	Data structure revision
n*24+2	Self-test number
n*24+3	Self-test execution status
n*24+4~n*24+5	Life timestamp
n*24+6	Self-test failure check point
n*24+7~n*24+10	LBA of first failure
n*24+11~n*24+25	Vendor specific
.....
506~507	Vendor specific
508	Self-test log pointer
509~510	Reserved
511	Data structure checksum

Table 22: Self-test Log Structure

For Table 22: Self-test Log Structure N is 0 through 20. The data structure contains the descriptor of the Self-test that the device has performed. Each descriptor is 24 bytes long and the self-test data structure is capable to contain up to 21 descriptors. After 21 descriptors has been recorded, the oldest descriptor will be overwritten with the new descriptor. The self-test log pointer points to the most recent descriptor. When there is no descriptor, the value is 0. When there are descriptor(s), the value is 1 through 21.

Byte	Content	Type
0-1	Data structure revision	Read and Write
2-9	Starting LBA for test span 1	Read and Write
10-17	Ending LBA for test span 1	Read and Write
18-25	Starting LBA for test span 2	Read and Write
26-33	Ending LBA for test span 2	Read and Write
34-41	Starting LBA for test span 3	Read and Write
42-49	Ending LBA for test span 3	Read and Write
50-57	Starting LBA for test span 4	Read and Write
58-65	Ending LBA for test span 4+	Read and Write
66-73	Starting LBA for test span 5	Read and Write
74-81	Ending LBA for test span 5	Read and Write
82-337	Reserved	Reserved
338-491	Vendor specific	Vendor specific
492-499	Current LBA under test	Read
500-501	Current span under test	Read
502-503	Feature flags R/W	Read and Write
504-507	Vendor Specific	Vendor specific
508-509	Selective self test pending time	Read and Write
510	Reserved	Reserved
511	Data structure checksum	Read and Write

Table 23: Selective Self Test Log Structure

10.7 S.M.A.R.T. WRITE LOG SECTOR (SUBCOMMAND D6H)

This command writes 512 bytes of data to the specified log sector. LBA Low and Sector Count Registers must be set to specify the log address and sector number to be written.

10.8 S.M.A.R.T. ENABLE OPERATIONS (SUBCOMMAND D8H)

This subcommand enables access to all SMART capabilities. Prior to receipt of a SMART Enable Operations subcommand, Attribute Values are neither monitored nor saved by the device. The state of SMART—enabled or disabled—will be preserved by the device across power cycles. Once enabled, the receipt of subsequent SMART Enable Operations subcommands will not affect any of the Attribute Values.

10.9 S.M.A.R.T. DISABLE OPERATIONS (SUBCOMMAND D9H)

This subcommand disables all SMART capabilities. After receipt of this subcommand the device disables all SMART operations. Non self-preserved Attribute Values will no longer be monitored. The state of SMART—enabled or disabled—is preserved by the device across power cycles. Note that this subcommand does not preclude the device's power mode attribute auto saving.

After receipt of the SMART Disable Operations subcommand from the host, all other SMART subcommands except SMART Enable Operations are disabled and will be aborted by the device returning the error code as specified in “SMART Error Codes”.

Any Attribute Values accumulated and saved to volatile memory prior to receipt of the SMART Disable Operations command will be preserved in the device's Attribute Data Sectors. If the device is re-enabled, these Attribute Values will be updated, as needed, upon receipt of a SMART Read Attribute Values or a SMART Save Attribute Values command.

10.10 S.M.A.R.T. RETURN STATUS (SUBCOMMAND DAH)

This subcommand is used to communicate the reliability status of the device to the host's request. Upon receipt of the SMART Return Status subcommand the device saves any updated Attribute Values to the reserved sector, and compares the updated Attribute Values to the Attribute Thresholds.

10.11 S.M.A.R.T. ENABLE/DISABLE AUTOMATIC OFF-LINE (SUBCOMMAND DBH)

This subcommand enables and disables the optional feature that cause the device to perform the set of off-line data collection activities that automatically collect attribute data in an off-line mode and then save this data to the device's nonvolatile memory. This subcommand may either cause the device to automatically initiate or resume performance of its off-line data collection activities or cause the automatic off-line data collection feature to be disabled. This subcommand also enables and disables the off-line read scanning feature that cause the device to perform the entire read scanning with defect reallocation as the part of the off-line data collection activities. The Sector Count Register must be set to specify the feature to be enabled or disabled:

Sector Count	Feature Description
00h	Disable Automatic Off-Line
F8h	Enable Automatic Off-Line

Table 24: Sector Count Register Definition

A value of zero written by the host into the device's Sector Count register before issuing this subcommand shall cause the automatic off-line data collection feature to be disabled. Disabling this feature does not preclude the device from saving attribute values to nonvolatile memory during some other normal operation such as during a power-on, during a power-off sequence, or during an error recovery sequence. A value of F8h written by the host into the device's Sector Count register before issuing this subcommand shall cause the automatic Off-line data collection feature to be enabled. Any other non-zero value written by the host into this register before issuing this subcommand is vendor specific and will not change the current Automatic Off-Line Data Collection and Off-line Read Scanning status. However, the device may respond with the error code specified in "SMART Error Codes".

11.0 SECURITY

11.1 DEFAULT SETTING

The SSD may be shipped with master password set (ASCII blanks) and the lock function disabled. The system manufacturer/dealer may set a new master password by using the SECURITY SET PASSWORD command, without enabling the lock function. Contact your Super Talent Representative for the master password value.

11.2 INITIAL SETTING OF THE USER PASSWORD

When a user password is set, the drive automatically enters lock mode by the next powered-on.

11.3 SECURITY MODE OPERATION FROM POWER ON

In locked mode, the SSD rejects media access commands until a SECURITY UNLOCK command is successfully completed.

11.4 PASSWORD LOST

If the user password is lost and High level security is set, the drive does not allow the user to access any data. However, the drive can be unlocked using the master password.

If the user password is lost and Maximum security level is set, it is impossible to access data. However, the drive can be unlocked using the ERASE UNIT command with the master password. The drive will erase all user data and unlock the drive.

12.0 SATA OPTIONAL FEATURES

12.1 POWER SEGMENT PIN P11

Pin P11 of the power segment of the device connector may be used by the device to provide the host with an activity indication. The activity indication provided by pin P11 is primarily for use in backplane applications.

12.2 ASYNCHRONOUS SIGNAL RECOVERY

The device and host PHY may support asynchronous signal recovery for those applications where the usage model of device insertion into a receptacle (power applied at time of insertion) does not apply.

When signal is lost, both the host and the device may attempt to recover the signal.

A host or device shall determine loss of signal as represented by a transition from PHYRDY to PHYRDYn, which is associated with entry into states LSI: NoCommErr or LS2:NoComm within the Link layer. Note that negation of PHYRDY does not always constitute a loss of signal. Recovery of the signal is associated with exit from state LS2:NoComm.

If the device attempts to recover the signal before the host by issuing a COMINIT, the device shall return its signature following completion of the OOB sequence which included COMINIT. If

a host supports synchronous signal recovery, when the host receives an unsolicited COMINIT, the host shall issue a COMRESET to the device. An unsolicited COMINIT is a COMINIT that was not in response to a preceding COMRESET, as defined by the host not being in the HP2:HR_AwaitCOMINIT state when the COMINIT signal is first received.

When a COMRESET is sent to the device in response to an unsolicited COMINIT, the host shall set the Status register to 7Fh and shall set all other Shadow Command Block Registers to FFh. When the COMINIT is received in response to the COMRESET which is associated with entry into state HP2B:HR_AwaitNoCOMINIT, the Shadow Status register value shall be updated to either FFh or 80h to reflect that a device is attached.

12.3 NATIVE COMMAND QUEUING

TBD

13.0 IDENTIFY DEVICE PARAMETERS

Word	Contents	Description
0	0C5Ah	General information
1	3FFFh	Number of logical cylinders
2	C837h	Specific configuration
3	0010h	Number of logical heads
4 – 5	0	Retired
6	003Fh	Number of logical sectors per logical track
7 – 8	0	Reserved
9	0000h	Retired
10 -19	XXXX	Serial number(20 ASCII characters)
20	0000h	Retired
21	4000h	Buffer Memory Size
22	3000h	Obsolete
23 - 26	XXXX	Firmware revision (8 ASCII characters)
27- 46	XXXX	Model number
47	8010h	Number of sectors on multiple commands
48	0000h	Reserved
49	2F00h	Capabilities
50	4000h	Capabilities
51 - 52	0200h	PIO Mode support
53	0007h	Reserved
54	3FFFh	Number of current logical cylinders
55	0010h	Number of current logical heads
56	003Fh	Number of current logical sectors per track
57	FC10h	Obsolete
58	00FBh	
59	0110h	Multiple sector setting
60	XXXXh	Total number of user addressable sectors (LBA mode only)
61	XXXXh	
62	0000h	Obsolete
63	0007h	Multi-word DMA transfer
64	0003h	Flow control PIO transfer modes supported
65	0078h	Minimum Multiword DMA transfer cycle time per word
66	0078h	Manufacturer's recommended Multiword DMA transfer cycle time per word
67	0078h	Minimum PIO transfer cycle time without flow control
68	0078h	Minimum PIO transfer cycle time with IORDY flow control
69 - 74	0	Reserved
75	001Fh	Queue Depth
76	0706h	Serial ATA capability
77	0000h	Reserved
78	004Ch	Serial ATA features supported
79	0048h	Serial ATA features enabled
80	00E0h	Major Version Number
81	0000h	Minor Version Number
82	346Bh	Command sets supported
83	7D21h	Command sets supported

UltraDrive GX Datasheet

Word	Contents	Description
84	4022h	Command set/feature supported extension
85	3469h	Command set/feature enabled
89	0000h	Time required for security erase unit completion
90	0000h	Time required for Enhanced security erase completion
91	0000h	Current advanced power management value
92	0000h	Master Password Revision Code
93	0000h	COMRESET result
94	0000h	Automatic acoustic management value
95	0000h	Stream minimum request size
96 - 99	0	Reserved
100 - 103	XXXX	Maximum user LBA for 48bit address feature set
104-105	0	Reserved
106	0000h	Physical sector size / logical sector size
107	0000h	Reserved
108 - 111	XXXX	Unique ID
112 - 116	0	Reserved
117 - 118	0	Words per logical sector
119 - 126	0	Reserved
127	0000h	Removable media status notification feature set supported
128	XXXXh	Security status
129 - 159	0	Undefined
160-254	0	Reserved
255	XXXXh	Integrity word
89	0000h	Time required for security erase unit completion
90	0000h	Time required for Enhanced security erase completion
91	0000h	Current advanced power management value
92	0000h	Master Password Revision Code
93	0000h	COMRESET result
94	0000h	Automatic acoustic management value
95	0000h	Stream minimum request size
96 - 99	0	Reserved
100 - 103	XXXX	Maximum user LBA for 48bit address feature set
104-105	0	Reserved
106	0000h	Physical sector size / logical sector size
107	0000h	Reserved
108 - 111	XXXX	Unique ID
112 - 116	0	Reserved
117 - 118	0	Words per logical sector
119 -	0	Reserved

Word	Contents	Description
126		
127	0000h	Removable media status notification feature set supported
128	XXXXh	Security status
129 - 159	0	Undefined
160-254	0	Reserved
255	XXXXh	Integrity word

Table 25: Identify Device Parameters

14.0 INSTALLATION

BEFORE GETTING STARTED

1. Back Up Your Data

VISUAL INSPECTION

1. Before unpacking and handling the SSD, discharge the static electricity by touching the metal chassis of your computer or by using an anti-static wrist strap
2. Inspect the box and device for the following
 - a. Box is damaged or water-stained
 - b. Any damage to the SSD

HANDLING THE SSD

1. Be cautious when unpacking, installing, and handling the SSD drive. Misuse of the SSD voids all warranty. Follow the succeeding instructions when managing the SSD
2. Follow all ESD pre-cautions
3. Always operate the SSD within environmental conditions
4. Never switch DC power to the drive by plugging an electrically live source cable into the drive's power connector
5. Ensure correct cable polarity whenever connecting the drive to the cable

INSTALLATION

System Requirements

To install the SSD in your computer, ensure that you have the following items:

1. Mounting Screws
2. SATA data and power cable (Sold separately)

Install the SSD

Follow these steps to install the SSD

1. Power down the PC
2. Remove the computer system outside cover
3. Connect a cable between the SSD and host
4. Replace the PC cover
5. Power on the PC
6. A BIOS sign-on message appears and displays a key sequence to enter the BIOS setup. Set up the BIOS to recognize the SSD.

USING THE SSD IN A MS-DOS OS

The SSD is already partitioned and formatted by NTFS, so if you want to install MS-DOS O/S on the SSD, it should be re-partitioned and re-formatted. After installing the SSD, it must be installed as a disk drive under DOS. Run the DOS commands as listed below and follow the instructions displayed for each command.

1. Run the DOS FDISK program to partition the SSD
2. Verify that the partition is active and ready for formatting
3. Run the DOS FORMAT command to high-level format the SSD

USING THE SSD IN A WINDOWS OS

No modifications need to be made to use the SSD in a Windows OS platform

USING THE SSD IN A LINUX O/S

No modifications need to be made to use the SSD in a Linux OS platform

USING THE SSD IN OTHER O/S

No modifications need to be made to use the SSD in other OS platforms

FOR MORE INFORMATION

For Technical Support:

If additional support is needed, please visit the Super Talent Web site at www.supertalent.com for the following topics:

- **Warranty Services:** Includes the warranty service policy and the RMA request forms.
- **Technical Information:** Includes product data sheets and various SSD whitepapers.
- **Tools Section:** Includes frequently asked questions (FAQs).

For More Information or Further Technical Support Please Contact:

Super Talent Technology
2077 North Capitol Avenue
San Jose, CA 95132
USA
Tel: +1 (408) 934-2560
Support: Support@supertalent.com
Sales: Sales@supertalent.com
OEM Sales: OEMSales@supertalent.com

CHANGE RECORD

Version	Release Date	Changes
1.0	December 16, 2008	Initial Release
1.1	March 16, 2009	<ul style="list-style-type: none">• Reformatted• Performance Details• Text Edits• Updated Part Number Tracking
1.2	April 1, 2009	<ul style="list-style-type: none">• Changed Voltage Supply Tolerance• Corrected Table Reference• Updated power specifications• Modified statement on ECC• Included FIT rate
1.3	May 7, 2009	<ul style="list-style-type: none">• Modified Speed Specifications

Table 26: Change Record